

# Forsheda 911

## Connector seal

### Seal Applications

The Forsheda 911 is a connector seal for flexible connection of pipes to concrete manholes and for passing pipes through other types of concrete walls. Holes can be drilled with a core bit.

### Function of Seal

The external ribs (1) are forced against the inside of the drilled hole when the seal is inserted into it. The plastic support ring (2) should be tapped into place with a rubber or plastic mallet. The pipe that is to be connected to the manhole is inserted through the coupling (3), (5), which has three or four collars, for different sizes of pipe. If a larger pipe is to be inserted then the surplus, smaller section of the coupling is cut away (5). The coupling is sealed to the pipe by means of a stainless steel jubilee clip (4). The clamping band that is supplied with the coupling will fit all the pipe sizes that the coupling is designed for.

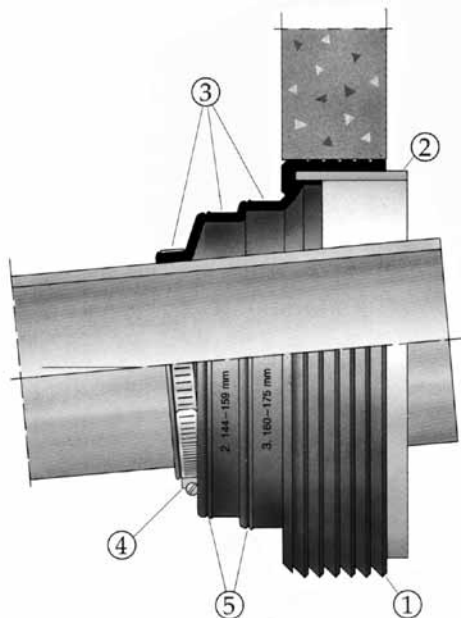

### Technical Data

Forsheda 911 meets the requirements of all current relevant European standards.

Test reports are available from Trelleborg Pipe Seals on request.

### Material

- Synthetic SBR or EPDM rubber
- Hardness 40±5 IRHD
- Approved in accordance with SS-EN 681-1
- Available in oil resistant material (NBR)

Detailed material specification is available at Trelleborg Pipe Seals on request.

### Clamping band

The clamping band is made of steel no SS 2333.

### Quality Assurance

- SS-EN ISO 9001:2000
- British Standard "Kitemark"
- CE- marking

### Marking and Dimensions

Each seal is marked with the outside diameter of the connecting pipes and period of manufacture. The box is labelled with corresponding data.

Technical data	Forsheda 911-1B	Forsheda 911-1	Forsheda 911-2	Forsheda 911-2B	Forsheda 911-3	Forsheda 911-4
Article no	1500421 *)	1602805	1562002	1782306	1632205	1774703
Connect. pipe diam. (1) Max. angular deflection	25 mm 40°	60-70 mm 45°	105-125 mm 45°	105-125 mm 45°	195-226 mm 35°	286-330 mm 30°
Connect. pipe diam. (2) Max. angular deflection	32 mm 35°	71-84 mm 30°	144-159 mm 30°	144-159 mm 30°	235-275 mm 30°	331-375 mm 15°
Connect. pipe diam. (3) Max. angular deflection	40 mm 33°	85-100 mm 15°	160-175 mm 15°	160-175 mm 20°	276-285 mm 15°	376-400 mm 10°
Connect. pipe diam. (4) Max. angular deflection	50 mm 30°	- -	- -	195-226 mm 10°	- -	- -
ØA, mm	24	60	107	107	202	300
ØB, mm	32	72	148	148	250	345
ØC, mm	40	86	166	166	286	390
ØD, mm	50	-	-	202	-	-
ØE, mm	123,5	123,5	223,0	279,0	314,0	449,0
ØF, mm	140,5	140,5	253,0	309,0	347,0	482,0
Drill Ø, mm	138 <sup>+0</sup> <sub>-1</sub>	138 <sup>+0</sup> <sub>-1</sub>	250 <sup>+0</sup> <sub>-2</sub>	305 <sup>+0</sup> <sub>-2</sub>	341 <sup>+0</sup> <sub>-2</sub>	475 <sup>+0</sup> <sub>-2</sub>

\*) EPDM

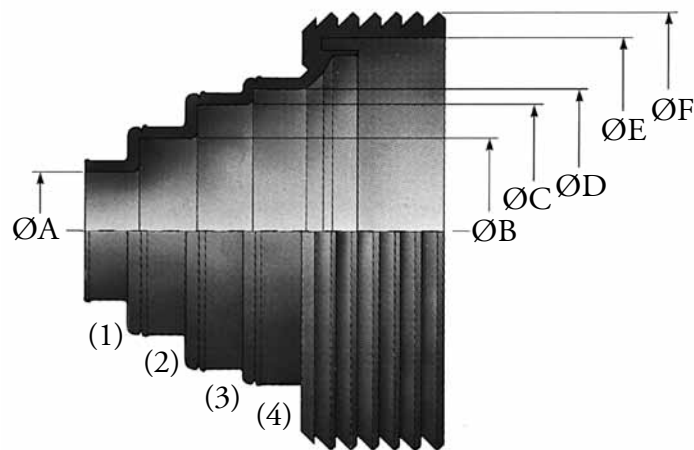

Pipes with Forsheda 911 should always be laid according to current standards and instructions. Contact Trelleborg Pipe Seals for joint design recommendations to meet current pipe standards.

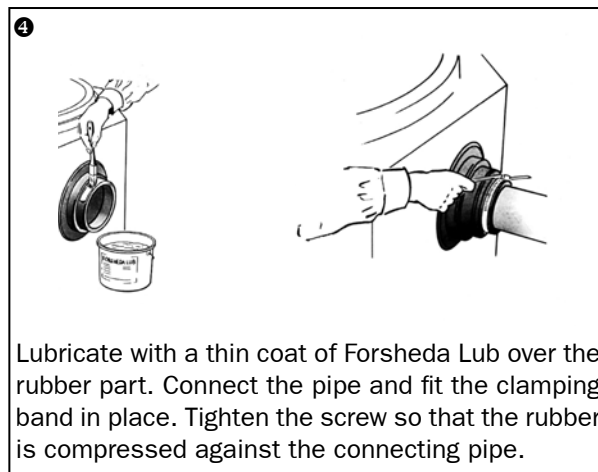
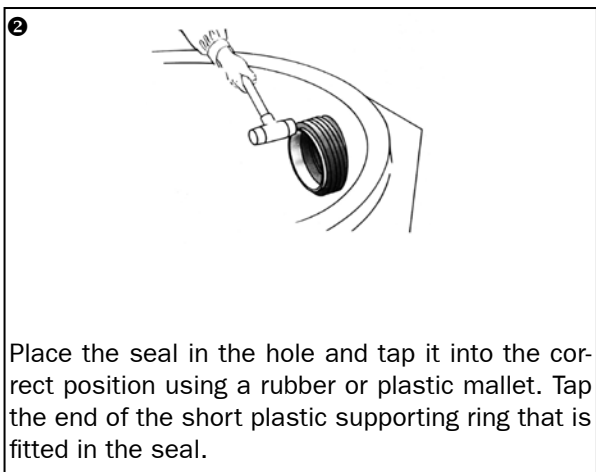
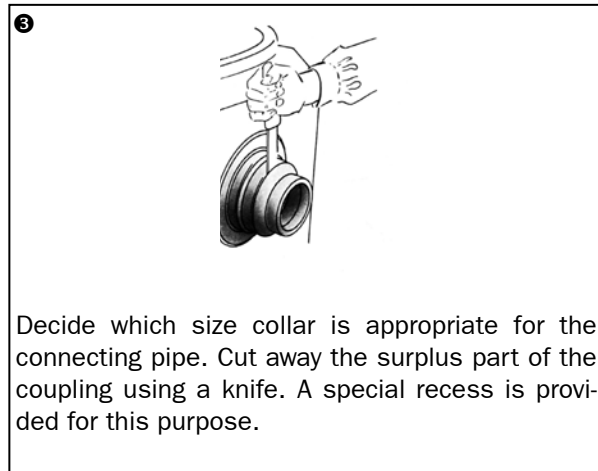
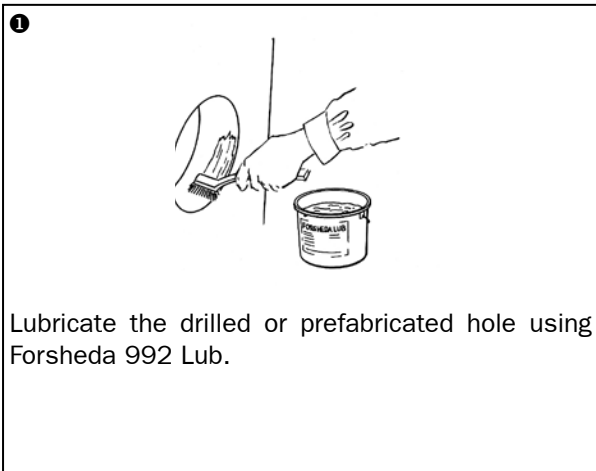

Example of authorities Trelleborg Pipe Seals cooperates with:



Trelleborg Pipe Seals Lelystad B.V.  
 P.O.Box 62, 8200 AB Lelystad, the Netherlands. Visiting address: Pascallaan 80, 8218 NJ Lelystad, the Netherlands.  
 Tel: +31(0)320267979, Fax: +31(0)320267980.  
[www.Trelleborg.com/pipeseals](http://www.Trelleborg.com/pipeseals)